



MODEL: **A2500N**



THE ADVANTAGE IS TO YOUR BOTTOM LINE

Temperature Capacity
-20°C*

Cubic Capacity
4.59m³

BODY DIMENSION

External length	2500mm
External width	1770mm
External height	1360mm
Internal length	2380mm
Internal width	1610mm
Internal height	1200mm
Pallet loading	2 Pallet capacity

Fitted body weight *490kg

PANELS THICKNESS

Roof/floor	80mm
Front wall	60mm
Side walls/side doors	80mm
Rear doors	60mm

Side door	Passenger side single door 1200 x 800mm
Rear door	Double - (left opens first)
Front wall frame	Universal to suit off engine drive units
Floor	Flo-coat floor
Internal light	1 LED light
Refrigeration	*Thermo King RV-200
Options	Cargo track Rear & side step Single piece aluminium chequer plate floor with scuff bands



Thermal efficiency 'K' VALUE .37 W/m²K tested to Australian Standard AS4982

Standard Inclusions

- High density polyurethane insulation
- European design
- European construction
- Low tare weight
- Higher legal payload
- Galvanised sub frame
- Recessed stainless door hardware
- Stainless door frames
- Anodised corner mouldings
- Long life EPDM rubber seals
- Internal LED light
- Moulded plastic mud guards
- Options available to suit customer requirements

Model No: A2500N-BCFI

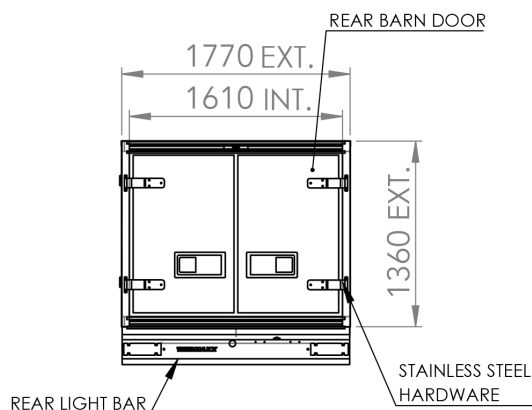
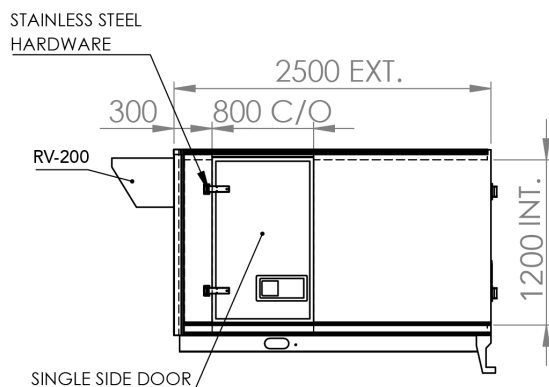

TRS/Thermaxx mission is one of continuous improvement, we reserve the right to change without notice or obligation to modify the technical specifications and aesthetic characteristics of the Thermaxx product. Please note: TRS/Thermaxx provides the information contained herein in good faith and changes may have been made to the product since this brochure went to print (01.3.2023). *Fitted body weight is an approximate weight based on the standard products supplied. Note: final weight may vary based on the type of cab chassis used, and or extra body equipment added. The 4-year warranty is for the Thermaxx Advantage products only. *²⁰C is based on an average ambient temperature. Note this can fluctuate depending on the region travelling and time of year - also the amount of door opening per day.